

Chimia 48 (1994) 127–137
 © Neue Schweizerische Chemische Gesellschaft
 ISSN 0009–4293

Proton Exchange Membranes by Radiation-Induced Graft Copolymerization of Monomers into *Teflon*-FEP Films

Bhuvanesh Gupta and Günther G. Scherer*

Abstract. A state-of-the-art in radiation-induced graft copolymerization of styrene and acrylic acid monomers into *Teflon*-FEP films is presented with a view to develop proton exchange membranes for various applications. This process offers an easy control over the composition of a membrane by careful variation in radiation dose, dose rate, monomer concentration, and temperature of the grafting reaction. By varying the nature and the amount of the grafted content, it is possible to achieve a membrane with desired physico-chemical properties. In this paper, a correlation among the degree of grafting, structural changes, and properties of graft copolymer membranes is discussed.

1. Introduction

A graft copolymer is a polymer which consists of one or more types of molecules as blocks connected as side chains to a main chain. These side chains should have constitutional or configurational features that differ from those in the main chain [1].



graft copolymer

In this graft copolymer molecule, the A chain, B_m and B_n are regular blocks. The A chain is the main chain, and B_m and B_n are the side-chain grafts.

The graft copolymerization is a process where, in a first step, an active site is created in a pre-existing polymer. This site could be a free radical or an active group which initiates the polymerization of a monomer leading to the formation of a graft copolymer.

There are various methods to activate the pre-existing polymer for the subsequent grafting, such as chemical, photochemical, and high-energy irradiation [2–4]. The most versatile way to produce graft copolymers for membrane development is the use of high-energy radiation, as discussed later. After modification, the polymer acquires some additional properties through the grafted component. This process, therefore, offers a unique way to combine properties of two highly incompatible polymers. The versatile nature of the radiation-grafting process is that the degree of grafting can be easily controlled by proper selection of radiation dose and dose rate [4]. Moreover, the grafting could be carried out into a thin polymer film which necessarily overcomes the post-grafting problems of shaping a grafted polymer into a thin foil for membrane application. This is the reason that a number of studies have been carried out to produce ion-exchange membranes by radiation-induced graft copolymerization of vinyl and acrylic monomers into various polymeric films for different applications. However, fluoropolymers as base films have generated considerable interest for membrane preparation because of the inherent thermal, mechanical, and chemical stability as compared to the hydrocarbon polymers [5–14]. There is enormous liter-

ature on various types of radiation and radiation chemistry of polymeric materials [15–17]. An excellent review on this topic has recently been published by Heger [17]. In the present paper, a state-of-the-art in the development of ion-exchange membranes by radiation-induced graft copolymerization of styrene and acrylic acid monomers into poly(tetrafluoroethylene-co-hexafluoropropylene), commonly known as *Teflon*-FEP or FEP, films is presented. The reason behind using FEP films as the base matrix is their high-radiation resistance as compared to the other fluoropolymers such as *Teflon*.

2. Radiation Grafting: General Aspects

2.1. Types of Radiation

Different types of high-energy radiation are available to be used for the grafting process [4][15–17]. These radiations may be either electro-magnetic radiation, such as X-rays and *gamma* rays, or charged particles, such as *beta* particles and *electrons*. The most widely used *gamma* radiation source is the Co-60 source which emits radiation of 1.17 and 1.33 MeV (mean value 1.25 MeV). This is because of the ease of its preparation, low cost, and fairly long half-life time of 5.3 years. Another *gamma* radiation source which could compete with Co-60 is Cs-137. This isotope is a fission product from the nuclear-energy plants and emits radiation of lower energy (0.66 MeV) than Co-60 (1.25 MeV).

Two different types of *gamma* radiation sources are available for irradiation [15]. One of the sources is a 'cavity-type' unit where the Co-60 unit forms a hollow cylinder and remains stationary. The sample is introduced into this cylindrical cavity by means of a moving drawer. A lead shielding prevents radiation from escaping. The second type of source is a 'cave type' where Co-60 is kept in a shielded container. The whole unit is kept underground, and the source moves out with the help of a moving belt for the irradiation of a stationary sample. The shielding material in such sources is a concrete structure. In some cases, the source is kept under water as well. Such sources offer a wide area for irradiation of samples and are, therefore, used on an industrial scale [18]. The 'cavity-type' sources are more compact and are widely used at a laboratory scale.

Synchrotron also offers the possibility to produce radiation over a broad range of the energy spectrum [19]. The photon en-

*Correspondence: Dr. G.G. Scherer
 Paul Scherrer Institute
 Electrochemistry Section
 CH-5232 Villigen-PSI

ergies of >0.1 MeV would be interesting for irradiation of fluoropolymers.

A large number of linear accelerators are available which produce *electrons* of energies in the range of 1–6 MeV. We refer the reader to the literature [4] [15–17] for more specific information.

From the grafting point of view, the basic difference in both types of radiation lies in terms of the high penetration power of the electromagnetic radiation [20]. Charged particles lose energy almost continuously through a large number of small energy transfers while passing through matter. However, photons tend to lose a relatively large amount of intensity by interaction with matter. This is the advantage of the electromagnetic radiation, such as *gamma* rays, that the fraction of photons, which do not interact with a finite thickness of matter, is transmitted with their original energy and direction (exponential attenuation law). Hence, the dose rate of radiation may be easily controlled by the use of a suitable attenuator without influencing the photon energy, which is a very important aspect in radiation-initiated polymerization [4]. Lead, with its half thickness value of 1.06, is the most widely used attenuator for *gamma* radiation due to its lower required thickness as compared to other attenuators.

As evident later, the distribution of grafts across the film thickness is a very important requirement for membrane preparation. Therefore, radical generation throughout the film thickness is necessary. Fortunately, all kinds of radiation discussed above have sufficient energy to

penetrate the bulk of the FEP films, which are usually of 25–200 μ thickness. This is the advantage of the high-energy radiation grafting over UV-induced photochemical grafting in the presence of a sensitizer. The latter cannot penetrate the bulk of the polymer film. As a result, the grafting involving UV radiation remains confined virtually to the surface layers of a film, leaving behind a bulk of the film unmodified [21–23]. At the same time, UV-induced grafting needs a photosensitizer which, if left behind in the film matrix, may act as an impurity. Photochemical grafting is, therefore, interesting for applications only where surface properties of a polymer need to be altered.

The absorbed radiation dose is defined as the amount of energy imparted to matter. The most recent unit of radiation is *Gray* (Gy) which corresponds to 10^4 erg/g [15]. For larger doses, *kilogray* (KGy) is used. The dose rate is, therefore, defined as the absorbed dose per unit time and is represented as Gy/min.

2.2. Methods of Radiation Grafting

The use of gamma rays or of an electron beam is to generate radicals in the grafting system. The following three different methods may be used for the radiation-initiated grafting process [4]: *a*) simultaneous radiation grafting, *b*) pre-irradiation in air (hydroperoxide method), and *c*) pre-irradiation in vacuum (trapped-radicals method).

A general schematic representation of the three methods is shown in *Fig. 1*. In simultaneous radiation grafting, the poly-

mer and the monomer are exposed to radiation at the same time. The radicals are, therefore, generated in both the polymer and monomer units. A chemical reaction of the monomer with the polymer backbone radical initiates the grafting reaction. Alternatively, a two-step grafting procedure may be adopted. In the first step, the polymer is exposed to radiation which leads to the formation of radicals on the macromolecular chain. If the irradiation is carried out in air, radicals react with oxygen leading to the formation of peroxides and hydroperoxides (hydroperoxide method). When contacted with monomer, the irradiated polymer initiates grafting by thermal decomposition of hydroperoxides. In the absence of air, these macromolecular radicals remain trapped in the polymer matrix and initiate the grafting in the presence of a monomer (trapped radicals method). Simultaneous radiation grafting is, therefore, a single-step process while pre-irradiation method involves two-steps.

The sensitivity of a polymer towards radiolytic degradation is an important factor before selecting the irradiation dose. A number of studies have been devoted to the structural changes and mechanism of degradation in fluoropolymers by high-energy irradiation (*e.g.*, [24–26]). The extent of degradation largely depends on the chemical nature of polymers. Among perfluorinated polymers, *Teflon* has been widely used for the grafting of various monomers [27–31]. This polymer has a very low resistance to high-energy radiation which causes degradation even for low doses of gamma radiation [32]. However, the copolymer poly(tetrafluoroethylene-*co*-hexafluoropropylene) (FEP) shows a much higher resistance against gamma radiation [33]. Therefore, it offers the possibility to carry out grafting under a wide range of radiation doses without much influencing its inherent mechanical properties. This is the reason that we attempted to develop cation-exchange membranes based on FEP films. There are few studies to develop membranes by radiation grafting of various monomers into FEP films [34–42]. These monomers fall into two categories: the one containing an active group in its molecule, such as acrylic or methacrylic acid and the other one which contains no functional group, such as styrene and which has to be functionalized in a post-grafting reaction. In this paper, we present various aspects of the membrane preparation by the grafting of both types of monomers into FEP films, but a great deal of emphasis is given to styrene grafting.

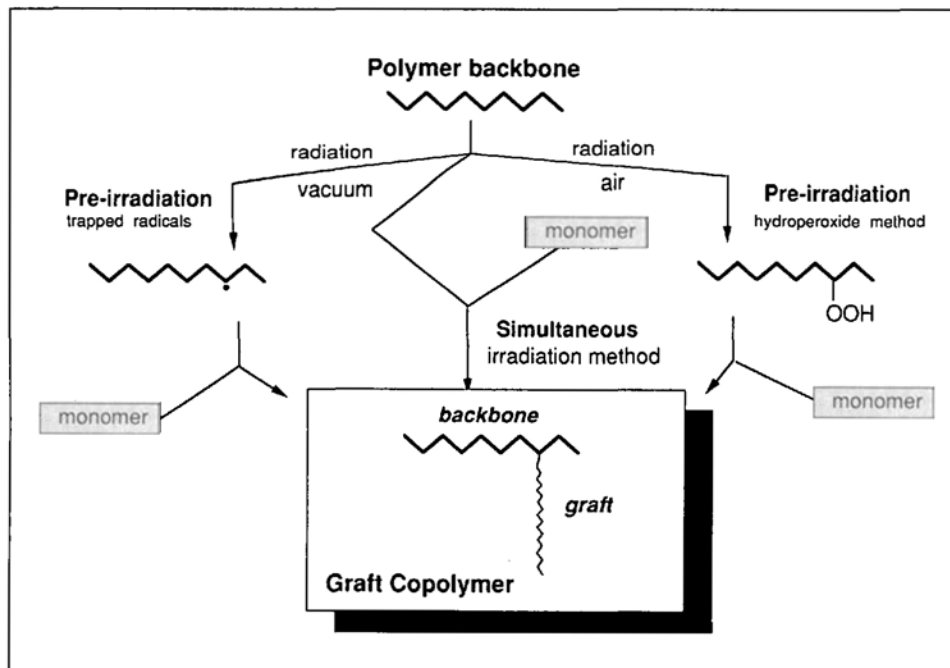

Fig. 1. Schematic representation of radiation grafting

3. Membrane Preparation

3.1. Grafting Method

The membrane preparation was carried out by the grafting of styrene and acrylic acid using two methods, *i.e.*, simultaneous and pre-irradiation grafting and details have been reported in earlier publications [37][42][43]. Diluents for the styrene and acrylic acid were benzene and H₂O, respectively. The degree of grafting corresponds to the percent increase in weight of the FEP films after the grafting reaction and was obtained as per following equation.

$$\text{Degree of grafting [\%]} = \frac{W_g - W_0}{W_0} \times 100$$

where, W_0 and W_g are the weight of the ungrafted and grafted films, respectively.

For acrylic-acid-grafted FEP films, no post-grafting reaction was needed to produce ion-exchange membranes. However, for styrene-grafted films, the sulfonation was carried out to introduce sulfonic acid groups as ionic sites. The degree of sulfonation was found to be ~100% [42].

3.2. Grafting Conditions vs. Degree of Grafting

As evident later, physico-chemical properties of a membrane are governed by the degree of grafting which in turn is controlled by the grafting conditions employed in a system. It, therefore, becomes of utmost importance to determine the influence of grafting parameters on the degree of grafting. The most important parameters are radiation dose rate, radiation dose, monomer concentration, temperature of the grafting reaction, and additives. The overall graft copolymerization process involves three kinetic steps which may be represented as follows.

Initiation:



Propagation:



Termination:

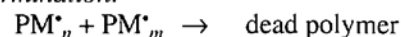

where, P^* is the primary radical site, PM^* is the initiated chain, M is the monomer unit and PM_n^* and PM_m^* are the growing graft chains. Any parameter that influences one or more of these three kinetic steps should lead to a variation in the degree of grafting. A detailed study of the kinetics of the grafting in FEP/styrene system is present-

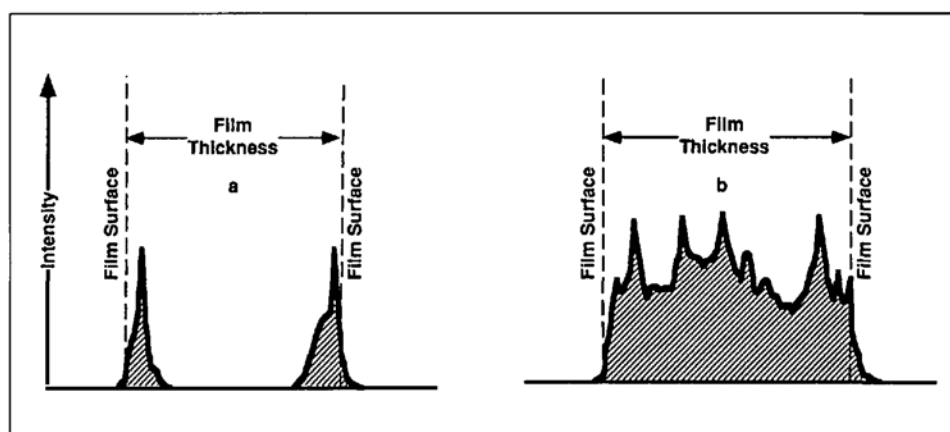

Fig. 2. Sulfur distribution in membranes with different degrees of grafting probed by microprobe analysis. a) 3%; b) 13%. Grafting conditions: dose, 60 KGy; monomer concentration, 60%; temperature, 60°; diluent, benzene.

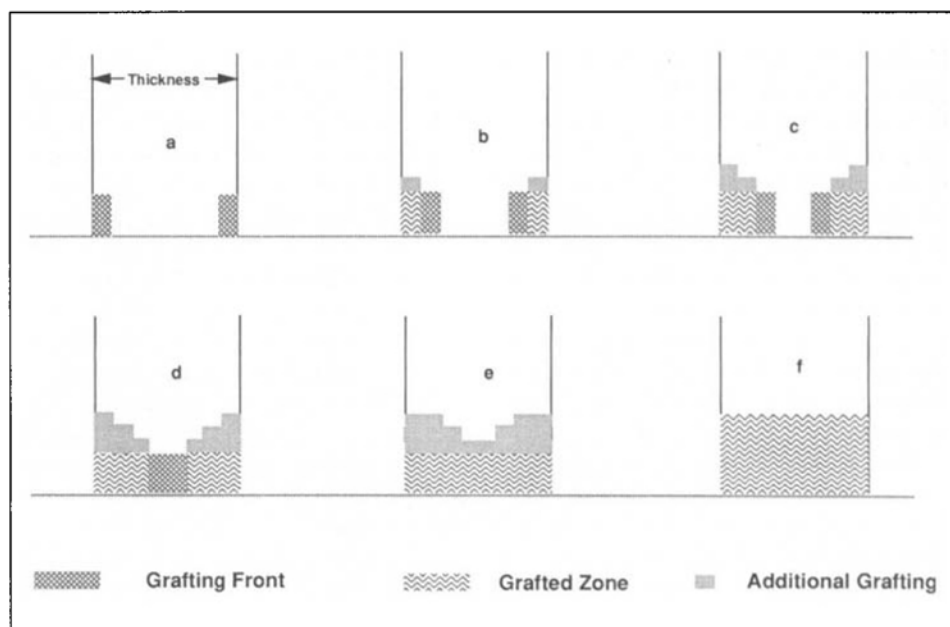

Fig. 3. Schematic representation of the 'Grafting Front' mechanism

ed in [43]. An extensive review of kinetic behaviour in different polymer-monomer systems is discussed by *Chapiro* [4].

Graft Penetration

Before discussing the influence of the grafting conditions, it is important to illustrate the mechanism of graft penetration into the FEP film. This will provide an important basis to understand the grafting process. As evident later, a homogeneous distribution of the grafted component across the FEP film is necessary for the membrane applications. Our kinetic study on the styrene grafting into FEP films as well as microprobe measurements on grafted and subsequently sulfonated films have revealed that the grafting takes place by the 'front mechanism' [43-45]. The sulfur distribution across the membrane matrix, as observed from microprobe measurements, is presented in Fig. 2. Owing to the

100% sulfonation, it may be assumed that the distribution of sulfur as obtained from the microprobe analysis, represents the distribution of grafted chains. It may be seen from Fig. 2 that, at a low graft level of 3%, grafts are located near the surface only. However, with the increase in degree of grafting (*ca.* 13%), grafts are incorporated across the film (see Fig. 2b). The two profiles on both sides differ to some extent as in Fig. 2a. It appears that the amount of the grafted polystyrene is slightly different which may not be significant in terms of absolute amounts, but this leads to a little bit different swelling of the two grafted layers. As a result, the swelling and diffusion of monomer from two sides within the film becomes somewhat different and leads to the slight variation in the profile on both sides of the film. The scattering in Fig. 2b indicates the graft content at various places across the FEP

film. This scattering is eliminated at higher degree of grafting of >19% (not shown in Fig. 2). These results indicate that the initial grafting takes place at the film surface only. This grafted layer swells in the reaction medium (styrene and benzene act as solvents for polystyrene grafts), and further grafting proceeds by the progressive diffusion of monomer through the monomer swollen grafted layer into the bulk till the 'grafting front' reaches the middle of the film.

The whole process of the grafting reaction involving the 'grafting front' mechanism is presented in Fig. 3. The figure shows the front movement from both sides of the film. It may be stated that stage *a* and *b* are obtained at a low graft level of ca. 3%. With the increase in the grafting, the two fronts move much closer and the front advances to stage *c*. As a result of the further movement of the front, the nonhomogeneous film of stage *c* is transformed into a homogeneous one (stage *f*). Based on our earlier results [45], it may be stated that stage *f* is achieved beyond a graft level of 13% for that particular system. The movement of the 'grafting front' to the middle and the growth of the chains in the grafted zone (*additional grafting*) proceed simultaneously. This mechanism represents a general scheme of the graft penetration in FEP films. Since, the degree of grafting vs. time depends on the grafting conditions employed in a system, the location of grafts at any time would also vary under different grafting conditions. The distribution of grafts shown in Fig. 2 cor-

responds to the conditions as mentioned over there. It may be mentioned here that the 'front mechanism' also operates for the grafting of acrylic acid into FEP films [35][37].

Monomer Concentration

The degree of grafting in pre-irradiation can be easily controlled by proper selection of grafting conditions, such as the monomer concentration. Fig. 4 shows the influence of the reaction time on the degree of grafting of styrene into FEP films at 60% [vol-%] monomer concentration. The grafting shows a sharp increase for the initial time and tends to level off beyond 4 h. However, the grafting does not reach saturation even after 56 h of reaction time, although, the increase is very little. Therefore, the degree of grafting at 56 h represents the final degree of grafting. From the results, it may be stated that a grafting time of 8–10 h is the most appropriate to achieve almost maximum degree of grafting. In acrylic acid grafting into FEP films (Fig. 4), however, the saturation is achieved within 2 h. It may be mentioned here that the grafting medium has a quite different composition comprising H₂O as diluent along with H₂SO₄ and FeSO₄ as additives. Each additive has its own influence over the grafting kinetics. Looking into the complexity of the grafting mechanism, it is difficult to offer any explanation to the different behaviour in two systems.

The results in Fig. 5 show that the higher the styrene concentration, the high-

er is the degree of grafting. Since, the grafting depends largely on the monomer availability to the radical sites within the film, at higher monomer concentration, the styrene availability into the film increases. As discussed in previous sections, one of the important requirements for the monomer diffusion into the bulk of the film is its high degree of swelling in the grafting medium. If the dilution of monomer has any impact on the swelling of the grafted matrix, monomer diffusion will be influenced accordingly. Fortunately, grafted polystyrene chains swell not only in its own monomer styrene but also in benzene and, therefore, regulate the monomer diffusion. As a result, the degree of grafting also increases. However, the nature of the solvent (S_x), which is used as diluent, plays an important role in determining the degree of grafting. If the solvent has a high chain transfer constant, the growing chain will be quickly terminated leading to low graft levels [4].

Deactivation:

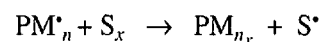

Another factor governing the degree of grafting is the solubility of the polystyrene homopolymer in the grafting medium. If the homopolymer dissolves in the monomer or solvent, it will increase the viscosity of the grafting medium. As a result, the monomer penetration into the film is considerably lowered.

One of the ways to overcome the prob-

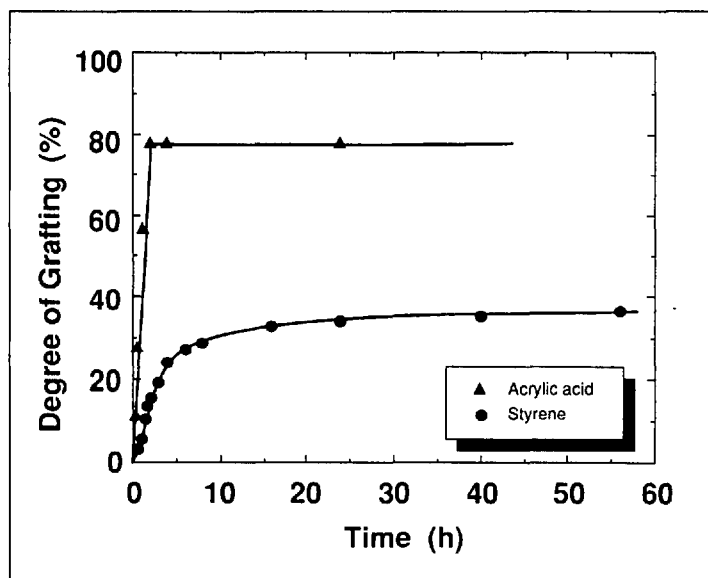

Fig. 4. Influence of time on degree of grafting in pre-irradiation grafting. ● styrene (grafting conditions: dose, 60 KGy; monomer concentration 60%, temperature, 60°; diluent benzene) and Δ acrylic acid (grafting conditions: dose, 40 KGy; monomer concentration, 30%; Mohr's salt 0.1%; H₂SO₄ 0.2 mol/l; temp. 60°; diluent, water).

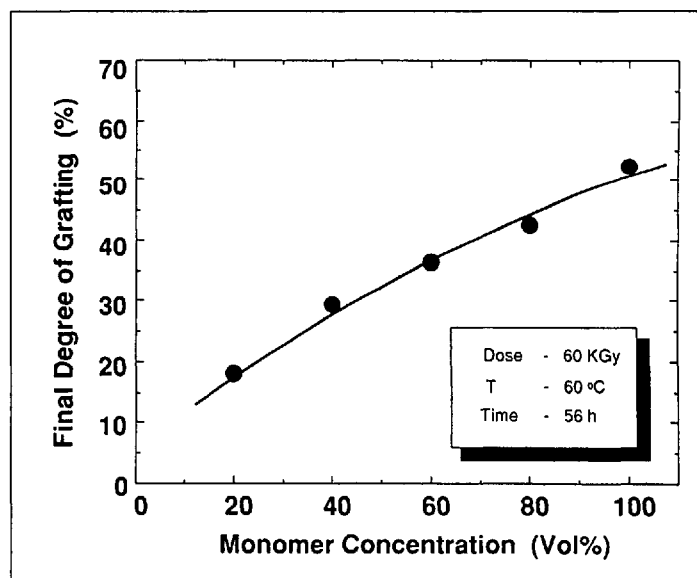

Fig. 5. Variation of degree of grafting with styrene concentration

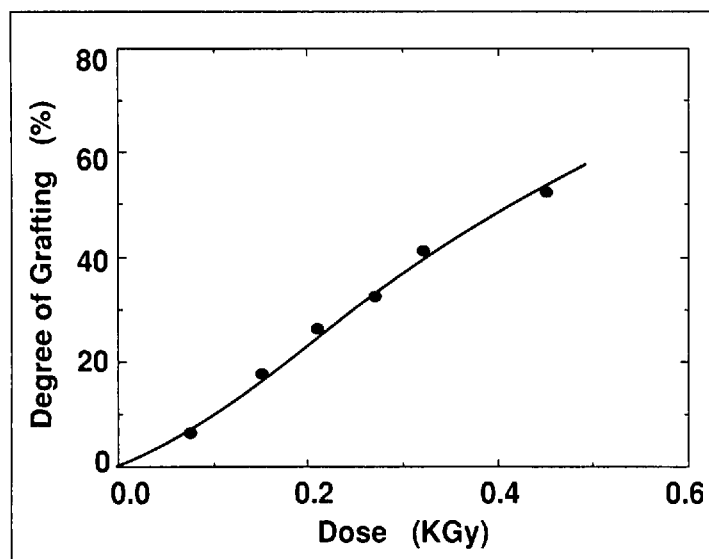

Fig. 6. Influence of radiation dose on degree of grafting. Simultaneous radiation grafting of styrene. Grafting conditions: dose rate, 0.5 Gy/min; temperature, 60°.

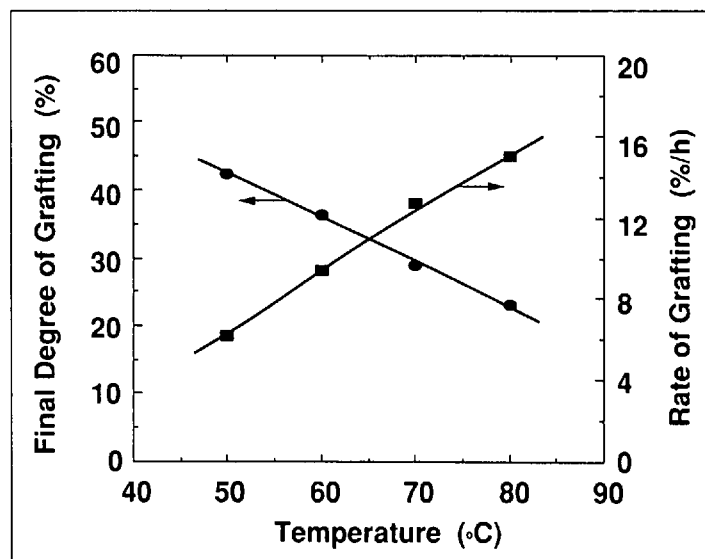
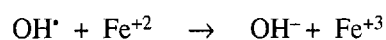

Fig. 7. Influence of the temperature on the final degree of grafting and the initial rate of grafting. Pre-irradiation grafting of styrene. Grafting conditions same as in Fig. 4.

lem of homopolymer formation is the use of ferrous salts in the grafting medium [35]. Fe²⁺ deactivates OH• radicals generated in the grafting system as per following equation.



However, the disadvantage of the ferrous salt as additive is that it deactivates the growing chains as well, which leads to the decrease in the degree of grafting.

Cross-linker

Cross-linkers are used in conjunction with the monomer to achieve certain desirable properties in a grafted membrane. However, the addition of a cross-linker to the grafting system leads to a decrease in the degree of grafting [43]. This is because of the fact that the very initial grafted chains get cross-linked. As a result, the mobility of macromolecular chains is considerably lowered. This decreases the swelling and hence the monomer diffusion into the bulk of the film. It is reflected in the rapid deactivation of growing chains leading to lower graft levels as compared to a system without cross-linker. Therefore, in the presence of a cross-linker, the grafting has to be carried out for a relatively longer time to achieve a comparable degree of grafting.

The major disadvantage using a cross-linker is that the rate of homopolymerization is enhanced as the cross-linker content in the grafting medium is increased. This leads to the quick gelation of the monomer in the grafting system, thereby limiting the time of the grafting reaction [43].

Influence of Radiation Dose

The basic difference between simultaneous and pre-irradiation grafting is that in the former case, radiation dose is a function of the grafting time. While in the latter case, radiation dose and grafting time are two independent parameters. The radiation dose has considerable influence on the degree of grafting for both the monomers used in our studies. The results in Fig. 6 on the simultaneous radiation grafting of styrene into FEP films show that the higher the dose, the higher is the degree of grafting [42]. This is essentially due to the higher number of radicals generated in the system at higher radiation dose which take part in the grafting reaction. Since, the monomer (M) is also exposed to radiation, considerable homopolymer formation takes place in the grafting medium which reduces the efficiency of the grafting system to a large extent.

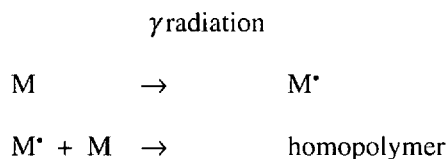

The most important requirement to achieve better graft yields in simultaneous grafting is a low radiation dose rate. The overall grafting trend in both pre-irradiation as well as simultaneous grafting remains the same. The higher the dose of radiation, the higher is the degree of grafting. However, in simultaneous radiation grafting, relatively lower doses are needed to achieve a degree of grafting comparable to pre-irradiation [42][43]. The reason behind such an observation is that in si-

multaneous grafting, the radical generation and the grafting reaction proceed simultaneously, leading to a more efficient utilization of radicals. While in pre-irradiation grafting, considerable radical-radical recombination takes place during the exposure of the film which results in a decrease in the radical concentration within the film.

Temperature

The temperature of the grafting reaction has a profound influence over the degree of grafting. The effect of the temperature on the initial rate of grafting and the final degree of grafting is presented in Fig. 7. The initial rate of grafting (as obtained, e.g., in Fig. 4, from the slope of the time-conversion plot for initial increase in the degree of grafting) increases with temperature. However, the final degree of grafting shows an opposite trend. It may be mentioned here that this behaviour was found to be similar for the grafting of styrene and acrylic-acid monomers into FEP films [37][43]. These results may be understood from the fact that the reactivity of radicals increases with increasing temperature and leads to the higher initial grafting rate. At the same time, once certain grafting has taken place, monomer has to diffuse through the swollen grafted layers before reaching and reacting with the radical sites. Due to the high viscosity of the monomer-swollen grafted zone, the grafting process is diffusion-controlled. Owing to the unavailability of a sufficient number of monomer radicals to the grafting sites, growing chains terminate faster at higher temperature leading to lower graft yields. At lower temperatures, not

only the grafting is slow, but also their termination is slowed down due to the lower reactivity of radicals, leading to the higher graft yields.

Nature of Radicals

The nature of radicals initiating the grafting in irradiated FEP is still a subject of discussion. When irradiation is carried out in vacuum, active centres are essentially P^{\bullet} radicals which remain trapped in the FEP matrix. It is evident from the studies of Hegazy *et al.* [41], that the grafting of acrylic acid into FEP films is initiated from P^{\bullet} radicals. However, irradiation in air should lead to the interaction of trapped radicals with atmospheric O_2 , resulting in the formation of POO^{\bullet} radicals. Studies of Chapiro and coworkers [34–36] on the grafting of acrylic acid and vinylimidazole into FEP films suggest, that even if the active centre is a peroxy radical, it is the P^{\bullet} or PO^{\bullet} radical which is involved in the grafting process. Authors' observation is based on the study that in the event, a peroxy radical initiates the grafting, the graft will be attached to the backbone in the form of a *P-O-O-graft* linkage. Such a structure would break away the grafted chain *via* the cleavage of O–O bond at higher temperatures. However, this is not the case and no weight loss takes place once a grafted film is heated to 80° (a temperature where peroxides decompose) under vacuum. These observations indicate that the initiating radical is a P^{\bullet} or possibly a PO^{\bullet} species.

Nature of Radiation

An interesting aspect of membrane preparation is that the nature of radiation

does not influence the degree of grafting into FEP films [37]. Fig. 8 shows the influence of the pre-irradiation dose on the grafting of acrylic acid into FEP films. It may be seen from the results that γ and electron beam irradiation result exactly in the same graft yields. These results indicate that the radical generation during exposure of the FEP film is identical irrespective of the nature of the radiation employed. It may be noted that the γ irradiation needs several hours or days of exposure of the FEP film. In contrast, electron beam exposure is carried out for a few min to achieve a similar dose. The electron-beam, therefore, offers the possibility of reducing the time of exposure which is an important factor for the commercial production of such membranes.

Pre-grafting Storage

The storage of irradiated films prior to grafting is an important factor which might influence the activity of films towards grafting. It has been found that irradiated FEP films stored at a temperature of -60° for four months retain their activity [43]. For FEP-*g*-polyacrylic-acid membranes, FEP films were stored at -20° for two weeks prior to irradiation. The degree of grafting did not show any decrease under the specified experimental conditions [37]. It indicates that free radicals generated during pre-irradiation are not destroyed during storage. This offers the possibility of exposing a large quantity of films in one single step and storing them at lower temperature for the subsequent grafting reaction in a later stage. This makes pre-irradiation grafting more attractive as compared to simultaneous where each reaction has

to be carried out in the radiation source. From the above discussion, it is evident that the degree of grafting depends on reaction conditions utilized in a system. It is, therefore, possible to produce a graft copolymer membrane with desired graft content by the proper selection of grafting conditions.

4. Structure and Properties of Membranes

4.1. Structural Changes in Membranes

The physical properties of these radiation-grafted membranes are considerably influenced not only by the nature and the amount of the grafted moiety but also by the structure that builds up during grafting as well as post-grafting processes. In semi-crystalline polymers, the *degree of crystallinity* plays an important role in determining the mechanical stability as well as the transport behaviour of the polymer. It has been observed that grafting of styrene and subsequent sulfonation leads to considerable changes in crystallinity [46][47]. The results presented in Fig. 9 show the variation in amorphous fraction in the membrane with increasing degree of grafting. As the grafting increases, amorphous content shows an increasing trend. It is caused by the cumulative influence of the dilution of inherent crystallinity by incorporation of amorphous polystyrene grafts into the noncrystalline region of the FEP film as well as of partial disruption of inherent crystallites [46][47].

The schematic representation of the crystallinity variation during the two-step membrane preparation is presented in Fig.

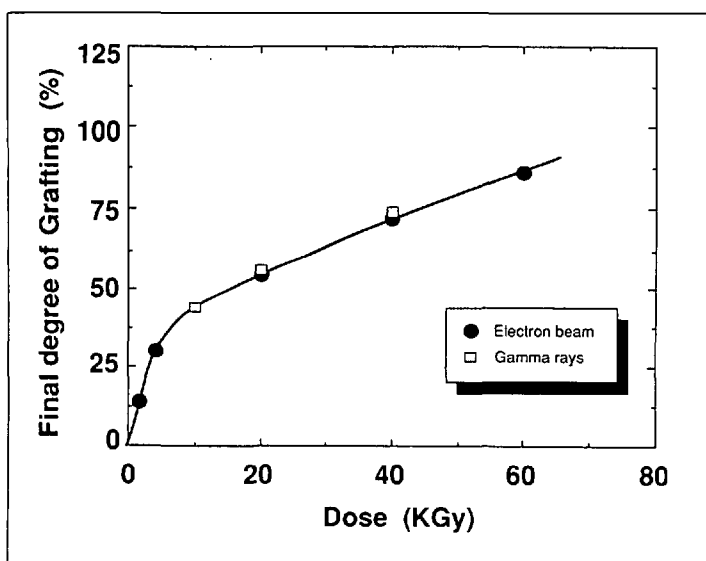

Fig. 8. Influence of the pre-irradiation dose on the degree of grafting of acrylic acid into FEP films. ● Electron beam and □ γ rays. Grafting conditions same as in Fig. 4.

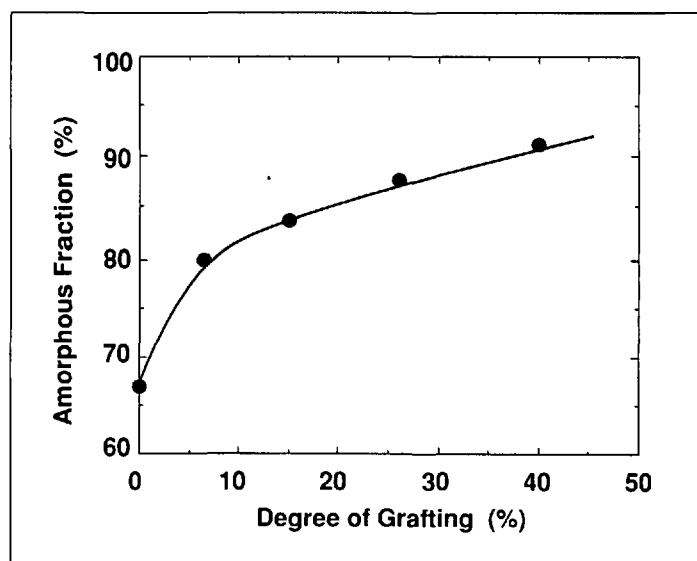

Fig. 9. Influence of the degree of grafting on the crystalline/amorphous ratio in membranes

10. The grafting proceeds by the incorporation of polystyrene grafts into the amorphous region of the membrane. Since, polystyrene grafts are amorphous in nature, this simply exerts a dilution effect on the inherent crystallites of the FEP matrix. The inherent crystallites, therefore, remain intact for the whole range of graft levels, 15–40% (Fig. 10 B). The second step of membrane preparation, i.e., sulfonation, leads to considerable changes in the crystalline region. Firstly, the sulfonation increases the weight fraction of the amorphous grafted component by further diluting the crystalline/amorphous ratio. Secondly, the grafting results in the attachment of polystyrene chains both in the amorphous region as well as to the crystallite surface. Once the membrane is swollen in H₂O, sulfonated polystyrene domains within the perfluorinated matrix expand. This leads to strong hydrophilic-hydrophobic stresses developing at the lamella-graft interjuncture. As a result, some of the grafted chains are cleaved off the lamellar surface leading to the partial disruption of the crystallite as shown in Fig. 10 C [46][47]. The cumulative influence of the dilution effect and crystal disruption is so high that the crystallinity in a membrane with 40% grafting decreases to almost one-third of its original value (Fig. 9). A similar behaviour in crystallinity changes of FEP-g-polyacrylic acid membranes was observed [48].

4.2. Physico-chemical Properties

As evident in the following sections, by careful variation of the degree of grafting, it is possible to control various important properties, e.g., ion-exchange capacity

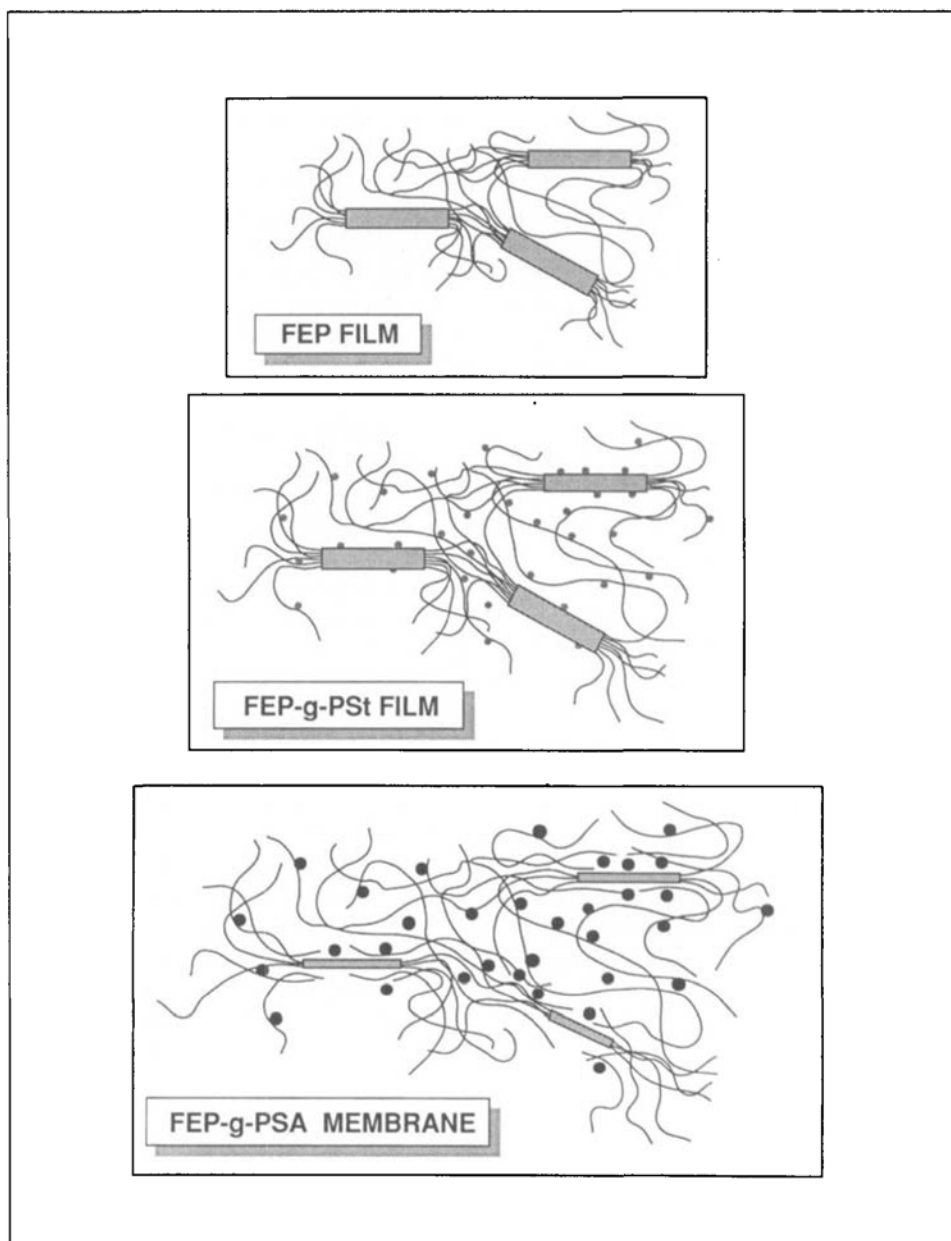

Fig. 10. Schematic representation of the crystalline changes in a graft copolymer film and a membrane

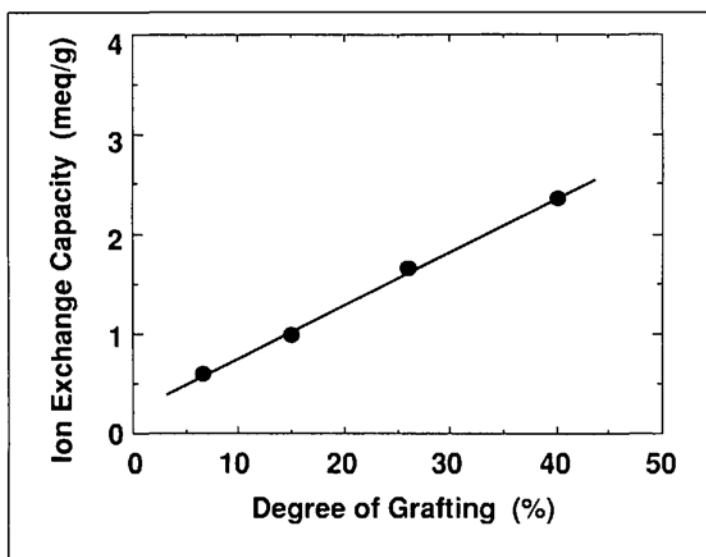

Fig. 11. Influence of the degree of grafting on the ion-exchange capacity and equivalent weight of membranes

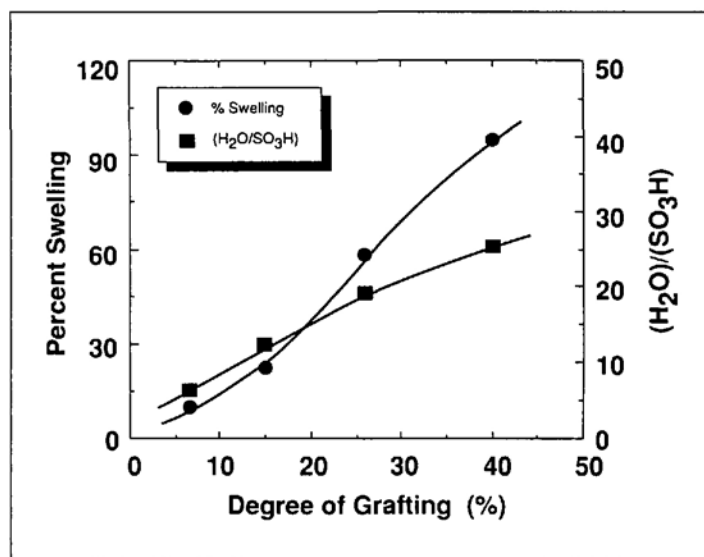

Fig. 12. Influence of the degree of grafting on the percent swelling and the H₂O/ionic-site ratio in membranes

ity, swelling, and resistivity of membranes. These properties are further altered by the presence of a cross-linker in the membrane matrix. A desired variation in the membrane properties could be achieved by proper selection of a cross-linker and its content in a membrane. One can, therefore, design a copolymer membrane according to the specific need for an application. In the following section, some physical properties as a function of the degree of grafting in membranes are described.

Ion-Exchange Capacity (IEC)

IEC is an important property which governs the hydrophilicity and H₂O content of membranes to a large extent. As the degree of grafting increases, the number of ionic sites in a membrane also increases. This is reflected in the higher ion-exchange capacity of the membrane (Fig. 11). This offers the possibility of preparing membranes with a desired ionic content by controlling the degree of grafting.

Glass transition T_g

T_g is another important characteristics of membranes. The physical properties of membranes, such as permeability and mechanical stability, are considerably influenced below or above this temperature. Such a behaviour is in fact associated with the higher mobility of molecular chains above the glass transition temperature (T_g). In other words, the membrane matrix acquires flexibility above T_g . We have found that T_g is strongly influenced by the amount of water present in a membrane. The higher the water content, the lower is the T_g in a membrane [47]. This is because of the plasticizing effect of H₂O over ionic sites in a membrane.

Swelling Behaviour

Swelling behaviour of a grafted membrane was determined by immersing a vacuum-dried membrane (ca. 1 torr at 80°) in H₂O and boiling it for 5 h. The H₂O uptake was obtained as the % increase in weight of the dry membrane. The results of membranes with different degrees of grafting are presented in Fig. 12. The higher the grafting, the higher is the swelling of the membrane. This is essentially due to the relative increase in the number of ionic sites (IEC of the membrane).

The most interesting feature in Fig. 12 is that the number of H₂O molecules per ionic site increases considerably with the increase in the degree of grafting. For an increase in the grafting from 6.5 to 40%, the hydration number increases from 6 to 25. These results simply cannot be explained by the chemical changes occurring during grafting and subsequent sulfonation, *i.e.*, increase in the ion-exchange capacity. We have observed that the ionic content per unit volume of wet membranes remains almost constant [42]. These results may, therefore, be understood from three factors operating in the system, *i.e.*, increase in the ionic content, increase in the hydrophilicity of the matrix, and decrease in the crystallinity in a membrane [45]. As the ionic content increases, the H₂O uptake in a membrane would also increase. Moreover, the sulfonated polystyrene grafts are hydrophilic in nature and remain distributed randomly in the FEP matrix. This results in the enhancement of the fractional hydrophilicity of the membrane as the degree of grafting increases. At the same time, crystallinity decreases with increasing grafting, as discussed above. On one hand, the enhance-

ment of hydrophilicity makes the membrane structure more amenable to H₂O molecules. On the other hand, the decrease in crystallinity leads to a membrane structure more permeable to diffusing species. As a result, the swelling of membranes increases to such an extent that it is reflected in the higher H₂O/ionic site ratio with the increasing degree of grafting.

Specific Resistivity

Specific proton resistivity of membranes, determined by *ac* impedance measurements [42], as a function of degree of grafting is presented in Fig. 13. Initially, the specific resistivity shows a sharp decrease and then a transition point at a certain degree of grafting, beyond that the resistivity does not show any appreciable change. We have observed that the initial grafting takes place at the film surface followed by the progressive diffusion of the monomer through grafted zones (as described in previous sections). It means that, for low levels of grafting, the film still remains ungrafted in the middle and, therefore, exerts a higher local resistance. However, as soon as the grafting front reaches the middle, this higher local resistance diminishes. Although, the grafting reaches the middle of the membrane at ca. 6% grafting, this is not yet sufficient to obtain low specific resistivity. From the results, it may be deduced that under the present grafting conditions, a minimum of ca. 15% grafting is necessary to achieve resistivity values of ca. 10 Ω cm. This graft level may, therefore, be termed as *critical degree of grafting*. However, a further but very slow decrease in resistivity beyond a graft level of 15% is essentially due to the higher H₂O content and more efficient

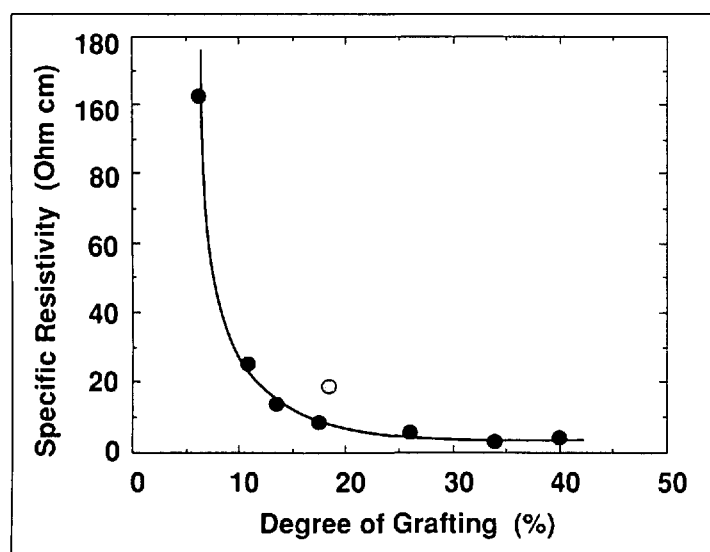

Fig. 13. Influence of the degree of grafting on the specific resistivity of membranes

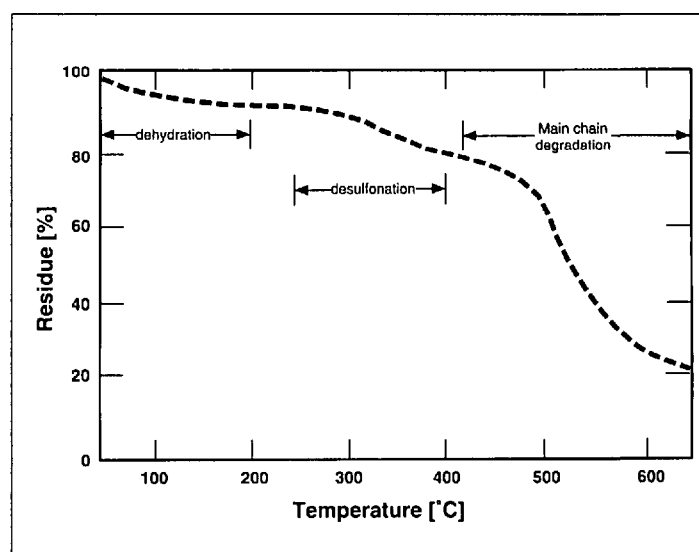

Fig. 14. TGA thermogram of FEP-g-polystyrenesulfonic-acid membrane with 40% degree of grafting

network formation involving H₂O domains in the membrane matrix. The presence of a cross-linker increases the resistivity of a membrane depending on the degree of cross-linking [44]. The open circle in Fig. 13 shows the resistivity of a membrane containing 4% DVB. In the presence of a cross-linker, the mobility of macromolecular chains in a cross-linked membrane is lowered which decreases the swelling of the matrix. As a result, the resistivity increases. It is interesting to note that the same trend of resistivity vs. degree of grafting is found for FEP-g-polyacrylic acid membranes [35]. However, it is important to note that, at a certain degree of grafting, membrane properties may vary to some extent depending on the grafting conditions. The reason behind such observation may be the relative change in the membrane structure under different preparation conditions [49].

Thermal Stability

Thermal behaviour of FEP-g-polystyrenesulfonic-acid membranes was evaluated by thermogravimetric analysis (TGA-FTIR-MS combination) and ion-exchange capacity (IEC) measurements. TGA studies under N₂ showed that membranes are stable up to 250° [50][51]. A clear demarcation of different degradative processes in the form of dehydration, desulfonation, and main chain degradation could be made (Fig. 14). Membranes undergo dehydration in a very broad range of temperature up to 150°. It is found that the desulfonation leads to the formation of a cross-linked structure. This is evident from the fact that the swelling of the heat-treated membrane decreases to a much higher level as compared to the loss in sulfonic acid groups. The results indicated that desulfonation proceeds by a mechanism where two sulfonic acid groups from the same or adjacent chains interact with each other, thereby eliminating SO₂ and H₂O [51]. As a result of the cross-linking of grafted domains, the resultant structure becomes rigid in nature (due to the formation of polysulfones etc.) and influences the swelling of the membrane matrix. In the final stage, the main chain (comprising fluorinated component and aromatic structures) undergoes degradation. The residue (ca. 20%) at the end of the thermogram was found essentially to be coke.

5. Applications

Radiation-grafted membranes of different base polymer-monomer combinations have generated considerable interest

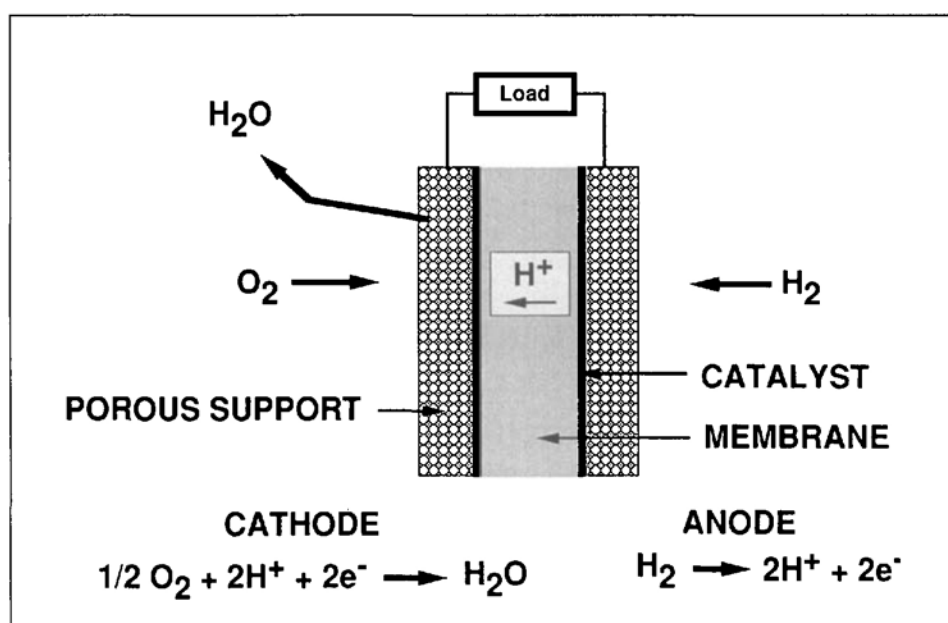

Fig. 15. Principle of polymer electrolyte fuel cell (PEFC)

in various fields of application, e.g., electrochemical energy conversion, separation processes, biotechnology, sensors, medicine, etc. There is enormous literature on these specific topics. Hence, only a brief account of membrane applications in some of these important fields will be presented below.

5.1. Electrochemical Energy Conversion

Main interest of the authors in the preparation and characterization of radiation-grafted FEP-g-polystyrenesulfonic acid (FEP-g-PSA) membranes, as described above, is their application as proton conducting solid electrolyte in H₂/O₂ fuel cells. A scheme of the membrane electrode assembly of such a fuel cell, operating at temperatures up to 100°, is displayed in Fig. 15 (cell housing not displayed) [52]. The water-swollen polymer membrane is sandwiched between two porous gas diffusion electrodes, whereby their electrocatalytic layers (highly dispersed Pt on C) face the membrane surfaces. Hydrogen is oxidized at the anode, protons migrate through the membrane, and combine with oxygen under the consumption of electrons. Electric power is delivered by such a cell depending on the external load. Typical power densities obtained by this type of fuel cell are in the range of 1 W/cm² with pure O₂ and beyond 400 mW/cm² with air at gas pressures up to 5 bar.

As evident from Fig. 15, the membrane serves as electrolyte as well as gas separator, which are equally important functions in that application. Hence, low specific resistivity as well as low gas permeation are of paramount interest. Due to

the particular environment of the membrane in such cells, e.g., hydrogen, oxygen, water, highly dispersed platinum, electrode potentials, etc. these membranes must have high oxidative, reductive, and hydrolytic stability.

Degrees of grafting beyond 15%, as shown above, are necessary to obtain specific resistivities in the range of 10 Ω cm (20°), which are a prerequisite for fuel cell application [42][53]. It has been shown, that cross-linking of the grafted polystyrene is of utmost importance for several reasons. Firstly, cross-linking with divinylbenzene reduces gas transport across the membrane as evidenced by the open-circuit potential in a cell [54]. This is due to the higher compactness (lower swelling) of the cross-linked polystyrene domains [55]. At the same time, membrane degradation, expressed as increase of the membrane resistance with time, is lowered. In contrast to these two beneficial effects, cross-linking with DVB also leads to undesirable higher specific resistivities. To balance these two contrary trends, the concept of double cross-linking has been developed for these membranes [56]. Cross-linking is carried out with two different cross-linkers, DVB to yield lower gas permeability and better fuel cell stability and TAC (triallylcyanurate) to improve swelling and hence, conductivity. This concept has resulted in a 'new class' of proton-exchange membranes which have the potential to substitute the currently used 'expensive' perfluorinated standard membranes in fuel cell applications with required lifetimes of a few thousand h (electric vehicles) [57].

Various types of radiation-grafted

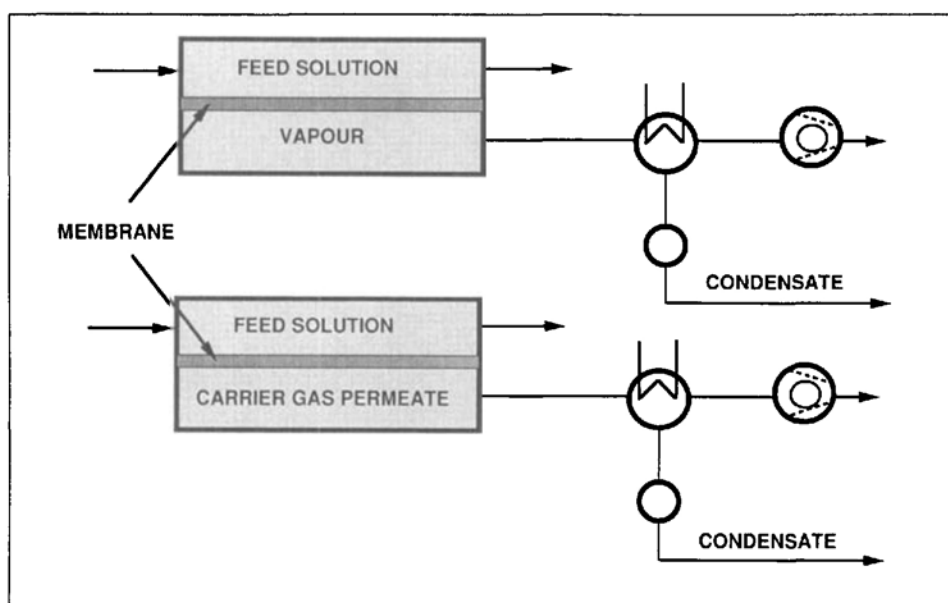

Fig. 16. Principle of pervaporation

membranes are used as separators in primary and secondary batteries [58]. This includes also combinations of hydrocarbon polymers (polyethylene, polypropylene) and monomers with and without an ionic functionality. Due to the less severe conditions in batteries as compared to fuel cells, the problem of membrane lifetime is by far not that important.

5.2. Separation Processes

A major application of FEP-*g*-polyacrylic-acid membranes has been in the separation of liquid mixtures by pervaporation [59]. With the advent of the necessity of reducing the energy requirements of unit operations in industries, pervaporation has been recognized as an alternative to the conventional methods of liquid separation. This process has been used extensively for the separation of H₂O/EtOH mixture obtained from the bio-mass fermentation. During this process, the liquid mixture is placed on one side of a membrane and the permeated product – the ‘pervaporate’ is removed in the form of vapour from the other side (Fig. 16). The driving force for the separation is maintained by the vapour pressure difference across the membrane. This is achieved by creating vacuum or by employing a carrier gas on the permeate side.

The flux and selectivity of a pervaporation membrane for various components in a mixture, *i.e.*, its permselectivity are mainly determined by the solubility and diffusivity of each of the components in the membrane matrix. FEP-*g*-polyacrylic-acid membranes have shown to be a good candidate for pervaporation processes. The degree of grafting has been found to have a profound influence over

the separation of H₂O/EtOH mixtures [60]. A successful utilization of these grafted membranes for the separation of various liquid mixtures has been reported by Neel and coworkers [61–63]. The variation in the flux and permselectivity for 4-vinylpyridine grafted *Teflon* membranes containing various degrees of grafting were evaluated for H₂O/-dioxane and H₂O/DMF mixtures. The liquid transport was enhanced as the amount of grafted component in the membrane increased. The selectivity, however, did not show much variation in a wide range of grafting ratios from 50 to 250%. Ellinghorst and coworkers [64] studied radiation grafting of various hydrophilic monomers, such as *N*-vinylpyridine and acrylic acid into different fluoropolymers. It was found that the flux increases with higher degree of grafting.

Electrodialysis (ED) is another separation technology where radiation grafted membranes can be employed [65][66]. ED is a membrane process which separates ions from (aqueous) solutions, whereby the separation is achieved by the migration of ions through ion-selective membranes under the driving force of an electric field. In an ED cell stack, cation- as well as anion-exchange membranes are arranged alternatively, ions are depleted from the feed solution and increased in the concentrate solution. Cation-exchange membranes employed are mainly sulfonated styrene- or acrylic-acid-grafted perfluoro or hydrocarbon polymers. The anion-exchange membranes are prepared by an amination process and contain quaternary ammonium ions. Demineralization of potable and brackish water and concentration of seawater are major applications,

minor applications are food processing, treatment of effluents, and others.

5.3. Sensors

Another interesting application of grafted membranes is in the field of sensors. Several studies have been made to develop membranes by radiation grafting of hydrophilic polymers such as polystyrene sulfonate and poly(4-vinylpyridine) (PVPy) into *Teflon* films [67][68]. Sakai *et al.* [68] have reported that the PVPy-grafted *Teflon* films show good sensitivity of their electrical resistivity to humidity and offer an excellent matrix to be used for a sandwich-type humidity sensor.

5.4. Bio and Medical Applications

Membranes obtained by radiation grafting are free from impurities of an initiator. It, therefore, makes them very useful in various biomedical fields, such as protein purification, drug immobilization, controlled drug delivery, and blood purification by dialysis.

One of the primary requirements of a membrane for medical application is its bio-compatibility. Since, tissues and blood remain in close contact with the membrane, it becomes of utmost importance to have a membrane surface with low interfacial free energy. Usually, an interfacial free energy of 1–3 dyn/cm can be considered satisfactory for blood compatibility [69].

Grafting of acrylic acid into FEP films leads to membranes with very low area resistance (0.20 cm² at 76% degree of grafting), which could be used for dialysis [70]. The low resistance in a grafted membrane is necessary to achieve better fluxes during dialysis. Certainly, the dialysis coefficient and the separation factor would depend on the nature and the degree of grafting in a membrane [9].

6. Conclusions

By careful variation of the grafting conditions and hence the degree of grafting, a proper control over membrane properties, such as ion exchange capacity, swelling, and resistivity can be achieved. The most important requirement for membrane development is the distribution of ionic groups across the film matrix. This is achieved at a certain degree of grafting, *e.g.*, *ca.* 6% for styrene/FEP, under the present experimental conditions. However, a higher degree of grafting is needed to obtain a much closer distribution of ionic domains and better network formation among water-swollen polystyrene domains

within the membrane matrix, a prerequisite for low specific resistivity.

Moreover, the grafting could be achieved in the form of a polymer already existing in the shape of a thin film. This eliminates the problem of shaping the grafted polymer into a thin foil required for membrane application. The exposed FEP film retains its activity even after a storage period of four months at -60° . This is the advantage of pre-irradiation grafting as compared to simultaneous. Therefore, a bulk of the film may be exposed once and stored before carrying out grafting without any decrease in grafting activity. Another advantage of pre-irradiation grafting is in terms of low homopolymer yield. The process of radiation grafting, therefore, offers an attractive way for commercial production of ion exchange membranes. These grafted membranes are of interdisciplinary nature in terms of their application in various areas.

The authors are grateful to Dr. O. Haas for interesting discussions and critical reading of this paper and to Dr. A. Chapiro for his continuous interest and constructive suggestions during this work. The authors wish to thank the Swiss Federal Office of Energy (BEW) for carrying out this work within the framework of polymeric membrane research for fuel cells. Thanks are also due to Du Pont (Luxembourg) for supplying FEP films and Mr. M. Steinemann for irradiation of samples. Sincere thanks to Dr. R. Kötzt for the artistic contribution to the manuscript.

Received: April 5, 1994

- [1] IUPAC Report on Nomenclature in Macromolecules, *Pure Appl. Chem.* **1974**, *40*, 479.
- [2] H.A.J. Battard, G.W. Tregear, 'Graft Copolymers', Wiley-Interscience, New York, 1976.
- [3] R.J. Ceresa, 'Block and Graft Copolymerization', Butterworth, London, 1962.
- [4] A. Chapiro, 'Radiation Chemistry of Polymeric Systems', Wiley-Interscience, New York, 1962.
- [5] A. Chapiro, G. Derai, A.M. Jendrychowska-Bonamour, *Eur. Polym. J.* **1971**, *7*, 1595.
- [6] J.L. Gineste, C. Iarguize, G. Pourcelly, *J. Appl. Polym. Sci.* **1994**, *51*, 63.
- [7] G. Ellinghorst, J. Fuehrer, D. Vierkotten, *Radiat. Phys. Chem.* **1981**, *18*, 889.
- [8] B. Gupta, F.N. Büchi, G.G. Scherer, A. Chapiro, *Solid State Ionics* **1993**, *61*, 213.
- [9] A. Elmidaoui, A.T. Cherif, J. Brunea, F. Duclert, T. Cohen, C. Gavach, *J. Membr. Sci.* **1992**, *67*, 263.
- [10] D. Martinez, R. Sandeaux, J. Sandeaux, C. Gavach, *J. Membr. Sci.* **1992**, *69*, 27.
- [11] G.K. Kostov, A.N. Atanassov, *J. Appl. Polym. Sci.* **1993**, *47*, 1269.
- [12] A. Chapiro, A.M. Jendrychowska-Bonamour, G. Morel, R. Oppelt, *Eur. Polym. J.* **1973**, *9*, 847.
- [13] S. Munari, F. Vigo, M. Nicchia, P. Canepa, *J. Appl. Polym. Sci.* **1976**, *20*, 243.
- [14] A. Chapiro, *Radiat. Phys. Chem.* **1977**, *9*, 55.
- [15] A. Saus, in 'Ullmanns Enzyklopädie der technischen Chemie', Verlag Chemie, Weinheim, 1982, Vol. 22, p. 253.
- [16] R. Mehnert, K.W. Bögl, N. Helle, G.A. Schreiber, in 'Ullmann's Encyclopedia of Industrial Chemistry', VCH Verlagsgesellschaft, Weinheim, 1993, Vol. A22, p. 471.
- [17] A. Heger, 'Technologie der Strahlenchemie von Polymeren', Carl Hanser Verlag, München-Wien, 1990.
- [18] Studer AG, Bereich Elektronenbestrahlung, CH-4658 Däniken.
- [19] W. Brefeld, P. Gürtler, in 'Handbook on Synchrotron Radiation', Eds. S. Ebashi, M. Koch, and E. Rubenstein, North-Holland, Amsterdam, 1991, Vol. 4.
- [20] H. Luig, C. Keller, W. Wolf, J. Shani, H. Mizka, A. Zybail, A. Gerve, A.T. Balaban, A.M. Kellerer, J. Griebel in 'Ullmann's Encyclopedia of Industrial Chemistry', VCH Verlagsgesellschaft, Weinheim, 1993, Vol. A22, p. 499.
- [21] Y. Yaggi, W. Schnabel, *Progr. Polym. Sci.* **1990**, *15*, 551.
- [22] I.R. Bellobono, F. Tolusso, E. Selli, S. Calgari, A. Berlin, *J. Appl. Polym. Sci.* **1981**, *26*, 619.
- [23] P.Y. Zhang, B. Ranby, *J. Appl. Polym. Sci.* **1991**, *43*, 621.
- [24] W. Bürger, K. Lunkwitz, G. Pompe, A. Petr, D. Jehnichen, *J. Appl. Polym. Sci.* **1993**, *48*, 1973.
- [25] E.R. Lovejoy, M.I. Bro, G.H. Bowers, *J. Appl. Polym. Sci.* **1965**, *9*, 401.
- [26] Z. Zhudi, L. Yunxia, J. Bingzheng, Y. Huai, T. Fengen, C. Xinfang, *Radiat. Phys. Chem.* **1993**, *41*, 467.
- [27] A. Chapiro, E. Gorden, A.M. Jendrychowska-Bonamour, *Eur. Polym. J.* **1973**, *9*, 975.
- [28] G. Burilo, A. Chapiro, *Eur. Polym. J.* **1986**, *22*, 653.
- [29] E.A. Hegazy, I. Ishigaki, J. Okamoto, *J. Appl. Polym. Sci.* **1981**, *26*, 3117.
- [30] S. Munari, F. Vigo, M. Nicchia, P. Canepa, *J. Appl. Polym. Sci.* **1972**, *16*, 1061.
- [31] I. Ishigaki, N. Kamiya, T. Sugo, S. Machi, *Polym. J.* **1978**, *10*, 513.
- [32] R.E. Iorin, in 'Fluoropolymers', Ed. L.A. Wall, Wiley-Interscience, New York, 1972.
- [33] N.E. Skeins, *Radiat. Phys. Chem.* **1980**, *15*, 47.
- [34] A. Bozzi, A. Chapiro, *Eur. Polym. J.* **1987**, *23*, 255.
- [35] A. Bozzi, A. Chapiro, *Radiat. Phys. Chem.* **1988**, *32*, 193.
- [36] X. Zhi-li, A. Chapiro, N. Schmit, *Eur. Polym. J.* **1993**, *29*, 301.
- [37] B. Gupta, A. Chapiro, *Eur. Polym. J.* **1989**, *25*, 1145.
- [38] X. Zhi-li, W. Gen-hua, W. Han-ing, C. Gyn, N. Min-hua, *Radiat. Phys. Chem.* **1983**, *22*, 939.
- [39] Y. Gen, *Desalination* **1987**, *62*, 265.
- [40] T. Momose, K. Tomiie, I. Ishigaki, J. Okamoto, *J. Appl. Polym. Sci.* **1989**, *37*, 2165.
- [41] E. A. Hegazy, I. Ishigaki, A.M. Dessouki, A. Rabie, J. Okamoto, *J. Appl. Polym. Sci.* **1982**, *27*, 535.
- [42] M.V. Rouilly, R. Kötzt, O. Haas, G.G. Scherer, A. Chapiro, *J. Membr. Sci.* **1993**, *81*, 89.
- [43] B. Gupta, F.N. Büchi, G.G. Scherer, *J. Polym. Sci., Polym. Chem. Ed.* **1994**, *32*, 1931.
- [44] B. Gupta, F.N. Büchi, M. Staub, D. Grman, G.G. Scherer, unpublished results.
- [45] B. Gupta, F.N. Büchi, G.G. Scherer, A. Chapiro, *Polym. Adv. Technol.* **1994**, in press.
- [46] B. Gupta, G.G. Scherer, *Angew. Makromol. Chem.* **1993**, *210*, 151.
- [47] B. Gupta, O. Haas, G.G. Scherer, *J. Appl. Polym. Sci.* **1994**, in press.
- [48] B. Gupta, G.G. Scherer, A. Chapiro, unpublished results.
- [49] B. Gupta, J. Halim, F.N. Büchi, G.G. Scherer, unpublished results.
- [50] B. Gupta, G.G. Scherer, *J. Appl. Polym. Sci.* **1993**, *50*, 2085.
- [51] B. Gupta, J. Highfield, G.G. Scherer, *J. Appl. Polym. Sci.* **1994**, *51*, 1659.
- [52] G.G. Scherer, *Ber. Bunsenges. Physik. Chem.* **1990**, *94*, 1008.
- [53] F.N. Büchi, B. Gupta, M.V. Rouilly, P.C. Hauser, A. Chapiro, G.G. Scherer, *Proc. IECEC* **1992**, *3*, 419.
- [54] F.N. Büchi, B. Gupta, O. Haas, G.G. Scherer, *Electrochim. Acta* **1994**, in press.
- [55] B. Gupta, G.G. Scherer, A. Chapiro, unpublished results.
- [56] F.N. Büchi, B. Gupta, G.G. Scherer, Swiss Pat. Appl. 02 636/93-6.
- [57] F.N. Büchi, B. Gupta, J. Halim, O. Haas, G.G. Scherer, *Extended Abstract, ECS Meeting, San Francisco, USA, May 22-27, 1994*.
- [58] Product Guide, Pall RAI, Inc., Hauppauge, N.Y., USA.
- [59] B. Gupta, A.K. Mukherjee, *Polym. Plast.-Eng. Technol.* **1990**, *29*, 299.
- [60] A. Bozzi, A. Chapiro, unpublished results
- [61] P. Aptel, J. Cuny, J. Jozefowicz, G. Moral, J. Neel, *J. Appl. Polym. Sci.* **1972**, *16*, 1061
- [62] P. Aptel, J. Cuny, J. Jozefowicz, G. Moral, J. Neel, *Eur. Polym. J.* **1973**, *9*, 877.
- [63] P. Aptel, J. Cuny, J. Jozefowicz, G. Morel, J. Neel, *J. Appl. Polym. Sci.* **1974**, *18*, 351.
- [64] A. Niemöller, H. Scholz, B. Götz, G. Ellinghorst, *J. Membr. Sci.* **1988**, *36*, 385.
- [65] W. McRae, in 'Process Technologies for Waste Water Treatment', Ed. S. Stucki, Plenum Press, New York, 1987, p. 45.
- [66] H. Strathmann, in 'Ullmann's Encyclopedia of Industrial Chemistry', VCH Verlagsgesellschaft, Weinheim, 1990, Vol. A16, p. 187.
- [67] Y. Sakai, Y. Sadaoka, K. Ikeuchi, *Sensors Actuators* **1986**, *9*, 125.
- [68] Y. Sakai, Y. Sadaoka, M. Matsuguchi, Y. Kanakina, M. Tamura, *J. Electrochem. Soc.* **1991**, *138*, 2474.
- [69] E. Ruckenstein, S. Gaurisanker, *J. Colloid Interf. Sci.* **1984**, *101*, 434.
- [70] B. Gupta, *Ind. J. Technol.* **1991**, *29*, 47.